

Energy efficiency challenge of waxy oil production by electric submersible pumps



I.A. Struchkov*, P.V. Roschin

Department of Development and Exploitation of Oil and Gas Fields, Saint-Petersburg Mining University, 21st Line, Saint Petersburg, Russian Federation

ARTICLE INFO

Article history:

Received 20 December 2016

Revised 11 April 2017

Accepted 12 April 2017

Available online 2 May 2017

Keywords:

Wax precipitation

Wax appearance temperature

ABSTRACT

In this paper the solid wax formation in two live oils of the Samara region fields on five operating pressures with different contents of high molecular substances were examined. For both oil samples a linear relation between wax appearance temperature and pressure was obtained. The study showed the inevitable transition of wax from the liquid phase to solid in the examined live oils under downhole conditions. This fact indicates a high probability of complications during well operations of these oilfields. If measures are not put in place to prevent the deposit formation in wells, there is a chance of complete blockage of tubing and flowlines by wax. These problems will lead to decrease in well flowrates to their shutdown, thereby increasing the operation costs to remove deposits and capital expenditures of oil production. Evaluation of the conditions for the wax precipitation in oil wells will allow to develop technology of prevention and remediation of previously formed organic deposits. The potential solid wax formation depth of both wells for minimum well flowrate of 20 m³ per day are calculated. The technology of continuous injection wax inhibitor in designed depth where formation of solid wax has not been observed yet is proposed.

© 2017 Tomsk Polytechnic University. Published by Elsevier B.V.
This is an open access article under the CC BY-NC-ND license.
(<http://creativecommons.org/licenses/by-nc-nd/4.0/>)

1. Introduction

Active agents which are used for tertiary recovery change the properties of the original oil in place (change viscosity, stabilize water-in-oil emulsions etc.). Furthermore, these surfactants can lead to both decreasing and increasing sizes of formed solid organic particles in oil [1–3]. Producing of changed oil is generally related to complications. The operator company in the field assesses the most possible production risks and develops methods for their prevention and remediation. Oil production from a majority of Russian oil fields is complicated by the organic scale formation in oil wells as a result of the thermodynamic disequilibrium in the oil dispersion system [4–7]. Identification and detailed study of factors that affect flow assurance is necessary for reliable oil production, technology development and validation of measures for the prevention of problems associated with the wax deposition in wells and porous media. Research aimed at the study of the equilibrium state of oil with dissolved high molecular weight

components and adjustment of the wax precipitation process plays an important part in the energy-efficient petroleum exploitation.

Wax appearance temperature (WAT) is the temperature at which the first wax crystals appear in oil [8]. Upon further cooling, a spatial structure is formed by wax in oil, leading to considerable increase in its viscosity. Deposition of solid organic particles on the internal surface of tubings and pipelines creates additional local resistance to the moving stream (pressure loses), leads to decrease in effective area of internal section of tubings, to increase in pumping pressure [9–11]. Brown [12] showed that increase in oil viscosity considerably reduces capacity, head and efficiency of electric submersible pump (ESP). This causes additional energy consumption for pumping oil through the tubing and flowlines. Because of high oil viscosity the actual production is located on the left side of the down thrust condition of ESP. It results in an overheat of the downhole motor and pump wear [13], so that downhole equipment had to be replaced, which increases capital expenditures of oil production. There are many ways to slow the wax accumulation process in well and remove previously formed deposits, the most popular of which is the chemical method due to its high technological effectiveness [8,14–18].

WAT depends on many parameters of the studied system, basic of which include oil composition, gas saturation and pressure

* Corresponding author.

E-mail addresses: StruchkovIA@gmail.com (I.A. Struchkov), paulforrest@yandex.ru (P.V. Roschin).

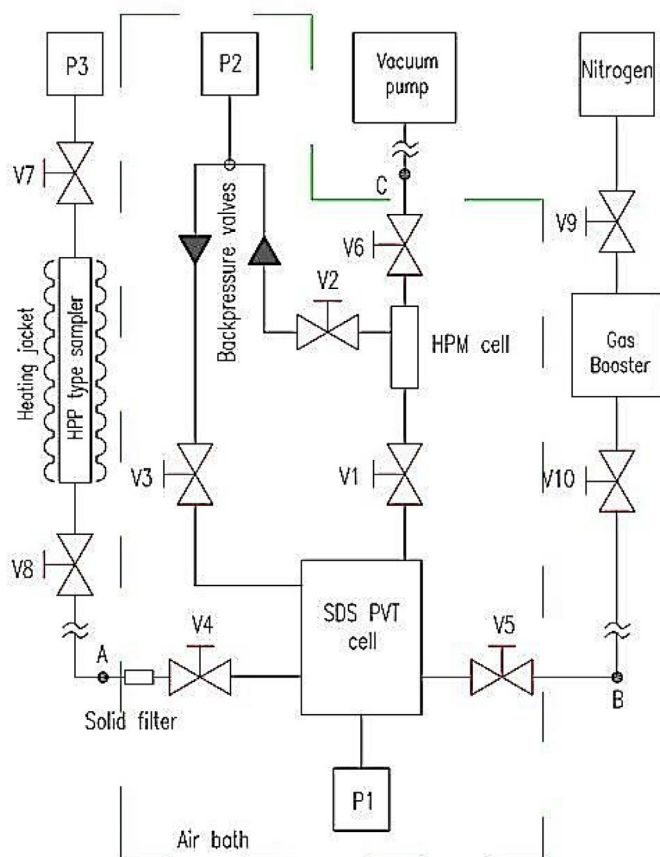

Fig. 1. Schematic diagram of the laboratory unit. P – pump; V – valve; A, B, C – connection points of the external equipment.

[19–21]. This study presents the comparison of wax precipitation conditions in two live oil samples of various compositions from two oil fields of the Samara region. Effect of high-molecular organic content (resins, asphaltenes and wax) and gas presence on the wax precipitation process in oil was evaluated. The objective of this research is to contribute results that lead to better understanding of the phenomenon in order to recommend appropriate preventive measures for organic deposition in oil wells.

2. Apparatus, fluid sample and experimental procedure

2.1. Apparatus

Study apparatus used for the experiments in this paper consist of an SDS PVT cell (solid detection system pressure-volume-temperature cell) of solid detection system [22,23] in which the energy of the transmitted light through an oil sample is measured – the main pump is set in this cell (P1 in Fig. 1) which supports a set pressure in the system; HPM cell (high pressure microscope cell) with in-built high pressure microscope [24] for taking micrographs of the oil sample under given conditions of temperature and pressure; a recirculation pump (P2 in Fig. 1), which agitates the analyzed fluid, homogenizing it; pipes and valves (V in Fig. 1). All system components are installed in the air bath, with operating temperature range set from 293 to 473 K with 0.1 K error.

Fig. 1 shows the connection diagram of elements of the research system.

2.2. Samples properties

Two live oil samples (sample A₁ and A₂) were collected from wells (A₁ and A₂) of two oil fields of the Samara region. Both

Table 1
Properties of the live oil samples.

Oil sample	A ₁	A ₂
Reservoir temperature (K)	321.3	320.5
Reservoir pressure (MPa)	26.2	18.4
Gas/oil ratio (m ³ /m ³)	45.6	38.7
Bubble point pressure (MPa)	6.6	3.9

wells are equipped with ESP. A₁ oil field was found in 1945 and has been exploiting since 1946. A₂ oil field was found in 1977 by exploratory well with the current depth of 1916 m and started producing in 2016 due to field infrastructure development. Wells are currently producing from oil-bearing formation with an API (American Petroleum Institute) gravity of 39.4 and 38.2, respectively. The producing formations are represented by sandstone with thickness of 2–8 m with interbeds of shale structure with thickness of 2–8 m. The production mechanism for these reservoirs is a water drive. Problems with the pumping equipment (cable burning, pumps wear) have been taking place in well A₁ during the last 10 years. Moreover, most of oil wells were shut in for workover on the average twice a year in order to remove the organic scale formation in the downhole equipment by hot oil flushing, solvent treatment or pigging operation. Well flow rate decreases lower than 100 m³/d and water cut increases up to 90% during the workover period.

The oil samples were delivered to the laboratory at controlled reservoir pressure and temperature. Live oil from field A₁ (sample A₁) has a resin content of 3.0 wt%, asphaltenes of 0.1 wt% and wax of 6.3 wt%. Live oil from field A₂ (sample A₂) has a resin content of 4.7 wt%, asphaltenes of 1.5 wt% and wax of 4.9 wt%. These oil fields are complicated by the organic scale formation in the downhole equipment.

The main properties of these oils are shown in Table 1.

2.3. Measurement procedures

The oil sample was heated to 358 K in the sampler and then homogenized at reservoir pressure for 12 h. Then the laboratory facility was heated to 358 K, all lines of the system were vacuumized and then nitrogen was pumped into the system, creating reservoir pressure using a gas booster. 50 ml of oil from the sampler was transferred to the unit at reservoir pressure using pumps P1 and P3 (Fig. 1). Then nitrogen and 10 ml of oil were bled slowly through the upper point of the system (point C in Fig. 1), after which only 40 ml of the live oil sample remained in the installation for experiments. Finally, the recirculation pump was put on and the oil was homogenized for 12 h. Laboratory studying of wax crystallization process in oil was performed on a mode of isobaric temperature depletion step by step. For both reservoir oils temperature decrease was conducted from reservoir temperature approximately to temperature on 10 K below the wax appearance temperature on five operating pressures. Before each experiment the oil sample was heated up to 358 K by way of paraffin melting-down and maintained at this temperature and operating pressure till thermodynamic equilibrium was reached. In all experiments, temperature was reduced at a rate of 1 K per h. Each experiment was carried out three times. The error of results did not exceed 3%.

3. Results and discussion

As a result of laboratory experiments with the two live oil samples from different oil fields, the following data, presented in Figs. 2 and 3, were obtained.

In Fig. 2 the data of particles grain size distribution which precipitated out of the live oil sample at step by step temperature

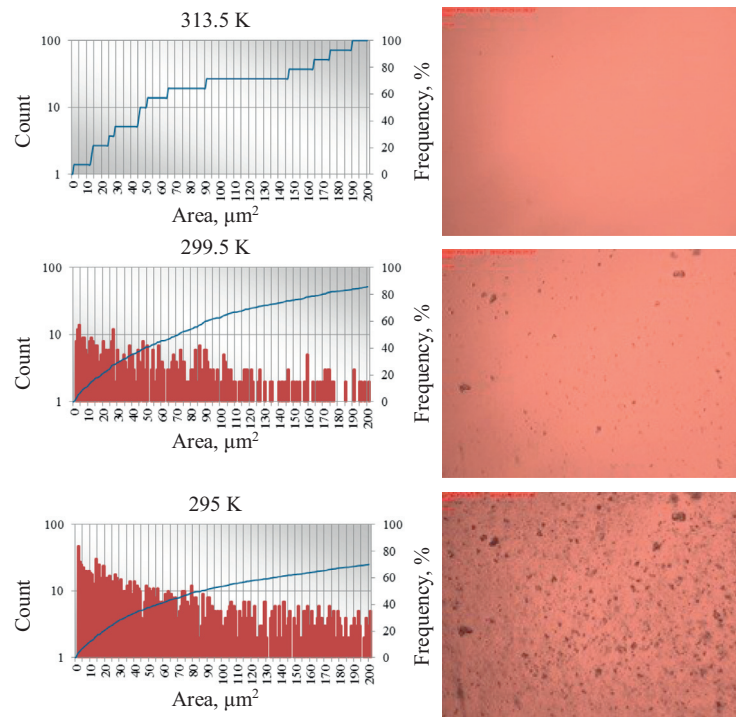

Fig. 2. Histograms of grain size distribution and micrographs of oil sample A₁ at isobaric (26.2 MPa) temperature depletion. Micrographs magnification $\times 100$.

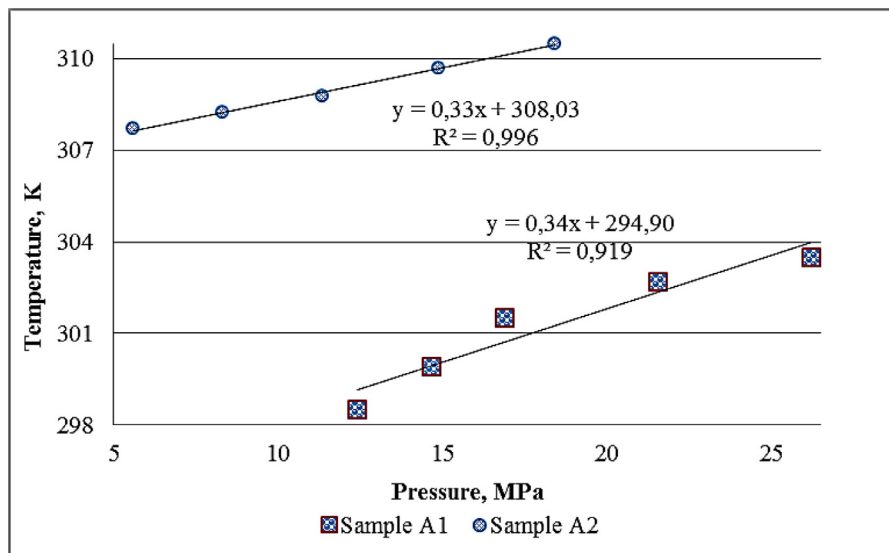

Fig. 3. WAT versus pressure for two live oil samples.

drop (at the left side of the figure) and the micrographs received by the microscopy under high pressure (at the right side of the figure) which demonstrate the oil sample states below the paraffin saturation point are shown. The table shows that the first wax particles appear at a temperature of 303.5 K, which was adopted as WAT. Further reduction in temperature leads to the formation of a gel-like dimensional structure formed by wax molecules.

Fig. 3 shows the relation between WAT and pressure for two live oil samples.

Fig. 3 shows that there is a linear relation between WAT and pressure [25] for both live oil samples. This relation is fully confirmed by the Clausius–Clapeyron equation [26] describing the first-order phase transition, which include crystallization of wax in oil. The physical significance of this process is the reduction

of entropy of the oil-dissolved wax system with pressure increase, which provides a growth in the paraffin saturation point. WAT for sample A₁ is on the average 9.5 K lower than for sample A₂ at equal pressures. The resulting difference in the wax appearance temperature of the studied oils is due to different gas saturation, wax content of oil, as well as their composition. Increase in gas saturation of oil and reduction in its wax content leads to a corresponding decrease in the paraffin saturation point. Oil degassing, which occurs during rise to the daylight surface, increases WAT due to a reduction in the solvent power of oil in relation to wax [27]. As such, exploitation of field A₁ compared to field A₂ is less exposed to problems associated with the wax precipitation under downhole conditions. However, in both oil fields, wax crystals will precipitate out from the oil in flowlines inevitably, especially dur-

ing operations in winter, creating the conditions for a pipe blocking by wax. Therefore, to prevent these complications, chemical treatment of wells in these fields is recommended. The wax inhibitor injection into the well to a depth where the formation of the paraffin wax has not occurred yet will slow down the wax deposition in the well, reduce the oil viscosity due to the formation of the dimensional structure of the wax molecules, and consequently, reduce energy consumption for pumping oil through flowlines. Inhibitor injection at a known depth will reduce its consumption, making operation of complicated wells more cost-effective. However, the invalid choice of the reagent injection depth (the depth where the temperature is below WAT) will not help to prevent the formation of organic deposits in the well leading to unwarranted expenses.

According to the calculations which are carried out by Struchkov and Rogachev [7] in this study solid wax particles formation depth in well A₁ is 520 m and in well A₂ is 1130 m (for minimum possible well flowrate of 20 m³ per day). In the previous study authors showed that increase in well flowrate leads to displacement of the formation depth of solid wax particles towards the wellhead, therefore, the minimum well flowrate provides for the highest solid wax particles formation depth. Authors offer continuous injection of wax inhibitor, which is the reaction product of unsaturated fatty acids and complex ethyleneamines, hydroxyl amines in an organic solvent (which showed high efficiency in the previous research), in the depth range from 550 to 600 m of well A₁ and from 1150 to 1200 m of well A₂, respectively. Proposed technology will allow to reduce consumption of wax inhibitor in comparison with conventional dosing in well annulus. It will lead to delay of wells waxing, and also decrease in oil viscosity that will promote increase in the ESP energy efficiency (reduction of power cost).

4. Conclusions

As a result of carrying out experimental research it was shown that conditions of wax sedimentation differ significantly in oils with various amounts of asphaltene, resins, wax and gas content. The reason for this difference is wax content of oils, their composition and gas saturation. Obtained data showed that increase in pressure leads to increase in WAT in both oils, the average difference in WAT is 9 K. For an oil sample A₁ a probable interval of solid wax particle formation in tubing is 520 m, while for an oil sample A₂ this value is 1130 m (for minimum well flowrate of 20 m³ per day). According to the authors' calculations the technology of continuous injection of the wax inhibitor in the depth range from 550 to 600 m of well A₁ and from 1150 to 1200 m of well A₂ is proposed. This technology will allow to reduce power expenditures for oil production and to increase efficiency of exploitation of these oil fields.

The achieved results can be used at the design stage of oil field development systems, and also for preparation of prevention methods of wax build-up in oil wells and remediate deposition in case it was not possible to avoid the given problems.

Acknowledgments

We acknowledge Dr. M.K. Rogachev for his assistance during the experiments. Finally, we would like to thank Saint-Petersburg Mining University (Saint Petersburg, Russian Federation) for providing laboratory equipment support and samples for this research.

References

- [1] B.M. Das, S.B. Gogoi, D. Mech, Micellar-polymer for enhanced oil recovery for Upper Assam Basin, *Resour.-Effic. Technol.* 3 (1) (2017) 82–87.
- [2] S.B. Gogoi, M. Kakoty, A study of CO₂ flooding on wave velocities in the Naharkatiya oil reservoir of Upper Assam Basin, *Resour.-Effic. Technol.* 3 (1) (2017) 101–112.
- [3] M.Y. Koroleva, T.Y. Nagovitsina, D.A. Bidanov, O.S. Gorbachevski, E.V. Yurtov, Nano- and microcapsules as drug-delivery systems, *Resour.-Effic. Technol.* 2 (4) (2016) 233–239.
- [4] L. Goual, *Petroleum Asphaltene*, INTECH Open Access Publisher, 2012.
- [5] M. Idris, L.N. Okoro, The effects of asphaltene on petroleum processing, *Eur. Chem. Bull.* 2 (6) (2013) 393–396.
- [6] G.A. Mansoori, Modeling of asphaltene and other heavy organic depositions, *J. Petrol. Sci. Eng.* 17 (1) (1997) 101–111.
- [7] I.A. Struchkov, M.K. Rogachev, Risk of wax precipitation in oil well, *Nat. Resour. Res.*, 2016, 1–7.
- [8] A.L. Machado, E.F. Lucas, G. González, Poly (ethylene-co-vinyl acetate) (EVA) as wax inhibitor of a Brazilian crude oil: oil viscosity, pour point and phase behavior of organic solutions, *J. Petrol. Sci. Eng.* 32 (2) (2001) 159–165.
- [9] Z. Guozhong, L. Gang, Study on the wax deposition of waxy crude in pipelines and its application, *J. Petrol. Sci. Eng.* 70 (1) (2010) 1–9.
- [10] R. Kirvelis, D.R. Davies, Enthalpy balance model leads to more accurate modelling of heavy oil production with an electric submersible pump, *Chem. Eng. Res. Des.* 81 (3) (2003) 342–351.
- [11] J. Robles, Application of advanced heavy-oil-production technologies in the Orinoco Heavy-Oil-Belt, Venezuela, SPE International Thermal Operations and Heavy Oil Symposium, January, Society of Petroleum Engineers, 2001.
- [12] K. Brown, *Artificial Lift*, Pen Wells Books, Tulsa, Oklahoma City, USA, 1985.
- [13] L. Bortolin, E. Uzcategui, New experience with electrical submersible pumps in heavy oil crude, SPE Latin America Petroleum Engineering Conference, January, Society of Petroleum Engineers, 1992.
- [14] O.O. Bello, S.O. Fasesan, C. Teodoriu, K.M. Reinicke, An evaluation of the performance of selected wax inhibitors on paraffin deposition of Nigerian crude oils, *Pet. Sci. Technol.* 24 (2) (2006) 195–206.
- [15] L. Dong, H. Xie, F. Zhang, Chemical control techniques for the paraffin and asphaltene deposition, SPE International Symposium on Oilfield Chemistry, January, Society of Petroleum Engineers, 2001.
- [16] K.S. Pedersen, H.P. Rønningsen, Influence of wax inhibitors on wax appearance temperature, pour point, and viscosity of waxy crude oils, *Energ. Fuel.* 17 (2) (2003) 321–328.
- [17] J.B. Taraneh, G. Rahmatollah, A. Hassan, D. Alireza, Effect of wax inhibitors on pour point and rheological properties of Iranian waxy crude oil, *Fuel Process. Technol.* 89 (10) (2008) 973–977.
- [18] K.S. Wang, C.H. Wu, J.L. Creek, P.J. Shuler, Y. Tang, Evaluation of effects of selected wax inhibitors on paraffin deposition, *Pet. Sci. Technol.* 21 (3–4) (2003) 369–379.
- [19] T.S. Brown, V.G. Niesen, D.D. Erickson, The effects of light ends and high pressure on paraffin formation, SPE Annual Technical Conference and Exhibition, Society of Petroleum Engineers, 1994.
- [20] W.B. Pedersen, A. Baltzer Hansen, E. Larsen, A.B. Nielsen, H.P. Rønningsen, Wax precipitation from North Sea crude oils. 2. Solid-phase content as function of temperature determined by pulsed NMR, *Energ. Fuel.* 5 (6) (1991) 908–913.
- [21] C.H. Wu, K.S. Wang, P.J. Shuler, Y. Tang, J.L. Creek, R.M. Carlson, S. Cheung, Measurement of wax deposition in paraffin solutions, *AIChE J.* 48 (9) (2002) 2107–2110.
- [22] J.N. McMullin, C.D. Eastman, C. Pulikkaseril, D. Adler, Measurement of the wax appearance temperature in crude oil by laser scattering, in: *Electrical and Computer Engineering*, 1999 IEEE Canadian Conference on, 3, IEEE, 1999, May, pp. 1755–1758.
- [23] K. Paso, H. Kallevik, J. Sjoblom, Measurement of wax appearance temperature using near-infrared (NIR) scattering, *Energ. Fuel.* 23 (10) (2009) 4988–4994.
- [24] D.L. Gonzalez, G.J. Hirasaki, A.K.M. Jamaluddin, W.G. Chapman, T. Solbakken, Impact of flow assurance in the development of a deepwater prospect, *Society of Petroleum Engineers* (2007), doi:10.2118/110833-MS.
- [25] J. Pauly, J.L. Daridon, J.A. Coutinho, Measurement and prediction of temperature and pressure effect on wax content in a partially frozen paraffinic system, *Fluid Phase Equilib.* 187 (2001) 71–82.
- [26] B.K. Sharma, *Engineering Chemistry*, 5, Krishna Prakasan Media (P) Ltd., Meerut, 2001.
- [27] B. Jiang, L. Qui, X. Li, S. Yang, K. Li, H. Chen, Measurement of the wax appearance temperature of waxy oil under the reservoir condition with ultrasonic method, *Pet. Explor. Dev.* 41 (4) (2014) 509–512.